

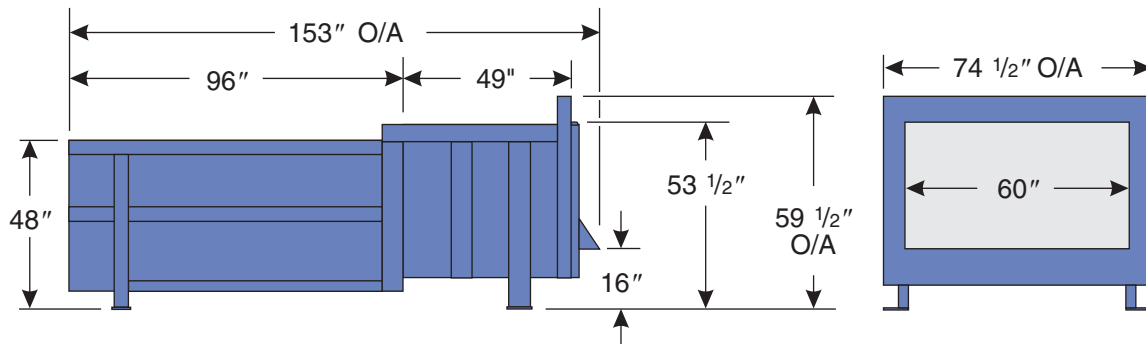

# CP-2202

- **2 Cu. Yd. Capacity, Heavy Duty, Industrial Compactor**
- **25" Ram Penetration**
- **101,800 Lbs. Compaction Force**
- **63 Second Cycle Time - Continuous Under Load**
- **Warranty - 3 Years Ram and Frame Weldment, 1 Year Electrical and Hydraulic Components**
- **Meets or Exceeds Current ANSI Z245.2 Safety Standards**



### Specifications

- Capacity (Cu. Yds.) ..... 2
- Cycle Time (Seconds) ..... 52
- Capacity Per Hour (Cu. Yds.) ..... 122
- Clear Top Opening L x W (Inches) ..... 45 x 58
- Ram Penetration (Inches) ..... 25
- Ram Face Dimensions (Inches) ..... 60 x 28
- Packing Force (Lbs.)
  - Normal ..... 84,800
  - Maximum ..... 101,800
- Operating Pressure (PSI)
  - Normal ..... 1,500
  - Maximum ..... 1,800

### Standard Features

- Frame: Floor 1/2" Abrasion Resistant Steel
- Floor Supports Structural Channel C3" x 4.1#
- Structural Tube TS 6" x 3" x 1/4"
- Side Plates 3/8"
- Side Supports Structural Tube TS 3" x 3" x 1/4"
- TS 6" x 3" x 1/4" & 6" x 4" x 1/4"
- Breaker Bar, 1-1/2" x 10" Vertical Bar
- Weldment 1" x 8" Horizontal Bar
- Cover Plate 1/4" Formed
- Ram Hold Down Bars 1" x 1" Bar
- Ram: Face Plate 3/4"
- Floor Plate 5/8"
- Side Plates 3/8"
- Top Plate 1/2"
- Top Supports C4" x 5.4#
- Guides Adjustable Nylatron Blocks
- Removable Access Panels
- Weatherhood/Safety Panels
- Ratchet Binders & Hooks: Heavy Duty Capacity
- Remote Power Unit
- Reservoir: 75 Gallon Capacity
- Oil - Suitable for Wide Temperature Range
- Oil Sight Gauge w/Thermometer
- Pump: 30 GPM, Continuous Displacement Vane Type
- Cylinders: (2) 6" Bore x 4.5" Rod x 74" Stroke
- UL Listed Electrical Components
- Motor: 20 HP 208 or 230/460 Volt 3 PH
- Controls In Main Panel:
  - Automatic Multicycle
  - Automatic Safety Retract
  - Automatic/Manual Selector Switch
  - Ram Position Switch
  - Full/Jam Automatic Shut-off w/Indicator
  - Key Lock On/Off Switch
  - Pull-To-Start/Emergency Push-To-Stop Button
  - Keyed Jog Controls

www.sp-industries.com

**SP Industries, Inc.**  
2982 Jefferson Rd. • Hopkins, MI 49328



**800-592-5959 • Fax: 269-793-7451**  
**E-mail: Info@sp-industries.com**

**CAUTION!** This Equipment Should Be Operated By Properly Trained Personnel. Improper Use, Misuse or Lack of Maintenance could cause injury to people and/or property. Photos used in this brochure are illustrative only. Due to its commitment to quality, SP Industries' specifications are subject to change without notice to accommodate improvements to its equipment. Information contained within this literature is intended to be the most accurate available at the time of printing.