

The Symbol of Excellence



Industries Inc.



CP-4101 Shown with
Optional Hinged Breaker
Bar Teeth

Standard & High Density Heavy Commercial/Light Industrial Compactors

Model CP-4101 & 4101-HD

4 Cubic Yard Stationary Compactors

- Reduce Hauling Costs - Compacting waste with a compactor that meets your needs will result in denser container loads and fewer trips to the landfill.
- Reduce Employee Labor - Use the compactor instead of your employees to break down large bulky refuse.
- Meets or exceeds current ANSI Z245.2 Safety Standards for Stationary Compactors.
- Heavy Commercial/Light Industrial Construction for applications with weekly container pulls.
- Large 75" x 55-5/8" Clear Top Opening.
- Engineering services for system designs that meet your individualized needs.
- American Manufacturer Electrical and Hydraulic Components - Specified for dependability, serviceability and nationwide availability.
- Outperforms and outlasts all other stationary compactors in their class.
- Industry's leading warranty
Three Years - Ram and Frame Weldment
One Year - Electrical and Hydraulic Components
Parts and Labor



ENVIRONMENTAL INDUSTRY
ASSOCIATIONS



WASTE EQUIPMENT
TECHNOLOGY ASSOCIATION



Printed on Recycled Paper

We Build Equipment the Old Fashioned Way — "With Pride"

Compactor Model	Mfr's. Rating (cu. yds.)	WASTEC Type Rating (cu. yds.)	Clear Top Opening (in.)		Chamber Length (in.)	Ram Stroke (in.)	Ram Penetration (in.)	Force Rating (Ram PSI at stated forces lbs.)		Hydraulic Syst. Pressure PSI		Ram Face (in.)		Volume Displacement (cu. yds. per hr.)	Motor H.P.	Cycle Time (sec.)	Discharge Opening (in.)			Base Unit Weight (lbs.)
			Length	Width				Normal	Maximum	Normal	Max.	Width	Height				Width	Height	Frm Gnd	
CP-4101	4	2.95	75.25	55.63	76.75	90	13	28.5/50,900	31.6/56,600	1800	2000	59.38	30	180	10	59	62	40	16	9,600
CP-4101-HD	4	2.95	75.25	55.63	76.75	90	13	38.8/69,300	43.1/77,000	1800	2000	59.38	30	236	20	45	62	40	16	10,300

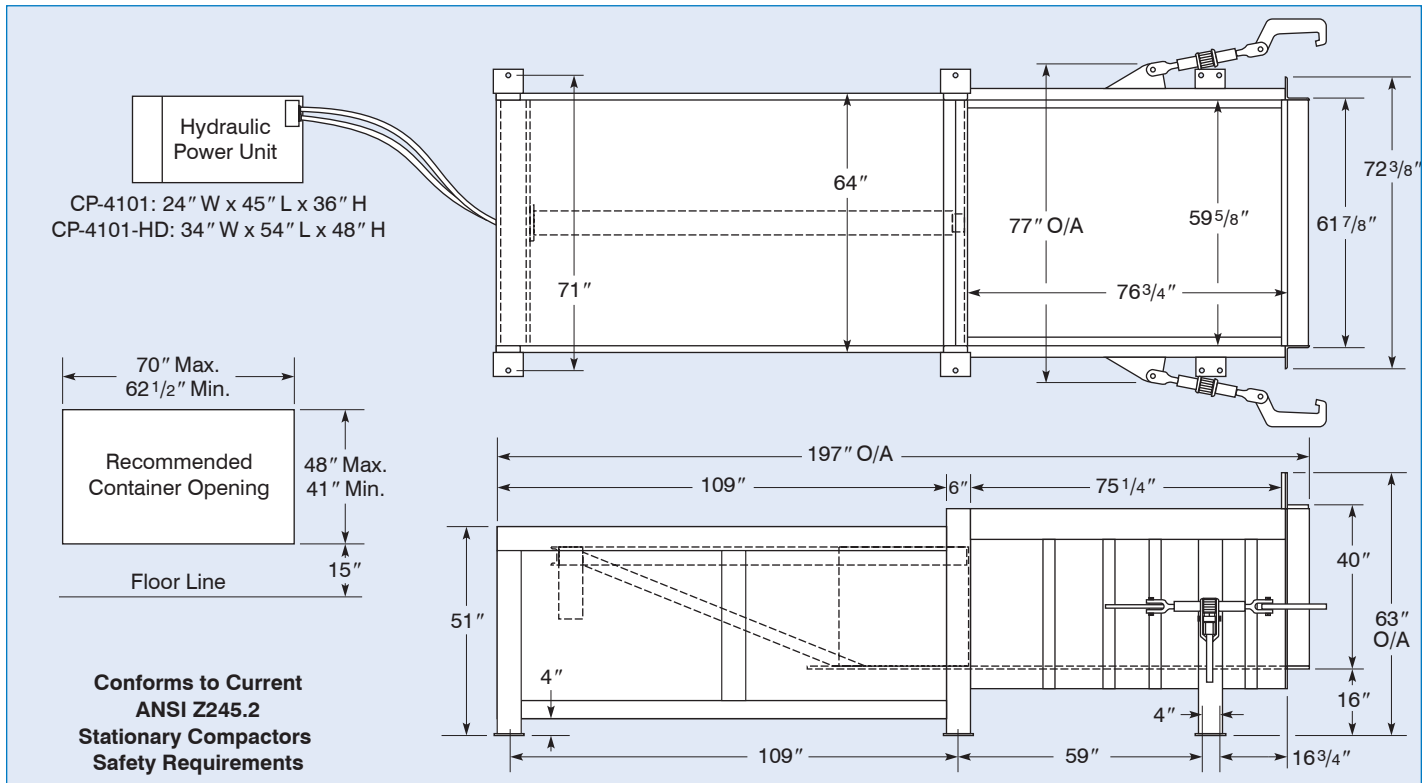

Standard Features

- Frame: Floor, Work Hardening Steel 1/2" Floor Supports (7) C4 x 5.4# Structural Tube (1) TS 6 x 3 x 1/4" Side Plates 3/8" Side Supports (4) TS 3 x 3 x 1/4" Structural Tube (2) TS 6 x 3 x 1/4" (1) TS 8 x 3 x 1/4"
- Breaker Bar: T-1 Tool Steel 1-1/2" x 8" Vertical Bar Weldment 1" x 5" Horizontal Bar
- Ram: Face Plate 3/4" Floor Plate 3/4" Side Plates 3/8" Top Plate 3/8" Top Supports (9) C4 x 5.4# Guides Adjustable Nylatron Blocks
- Cylinder: CP-4101 - (1) 6" B x 4.5" R x 90" S CP-4101-HD - (1) 7" B x 5" R x 90" S
- Motor: CP-4101 - 10 HP 208/230/460 V 3PH ODP CP-4101-HD - 20 HP 208 or 230/460 V 3PH ODP
- Pump: CP-4101 - 16 GPM Continuous Displacement CP-4101-HD - 30 GPM Continuous Displacement
- Reservoir: CP-4101 - 40 Gallons CP-4101-HD - 75 Gallons
- Remote Power Unit
- Oil - Suitable for a Wide Temperature Range
- Oil Sight Gauge with Thermometer
- UL Listed Electrical Components
- Controls in Main Panel
 - Key Lock On/Off Switch
 - Push/Pull Emergency Stop/Start Button
 - Auto Multicycle
 - Automatic Safety Retract
 - Automatic/Manual Selector Switch
 - Ram Position Switch
 - Full/Jam Automatic Shut-off with Indicator
- Removable Access Panels
- Ratchet Binder/Hooks: Heavy Duty Capacity



Standard 10 HP/16 GPM Power Unit for the CP-4101.

The Power Unit for the CP-4101-HD has a Similar Electrical Panel on a Larger Reservoir with a 20 HP Motor and a 30 GPM Pump.

Optional Features

- Decks - 750#, 10,000# & Special Capacities
- Safety Handrails & Toerails
- Safety Gate with Interlock
- Side or Rear Load Hopper
- Enclosed Hopper with Door
- Side or Rear Load Security Chute
- Full Enclosure
- Safety Interlock System
- Deodorizer Spray System
- UL Certified Panel and Controls
- Unattended Electric Start System
- Keyed Pinning/Boost Override System
- Advance Full Load Indicator
- TEFC Motor
- Low/Hot Oil Indicator with Shut-off
- Thermo Oil Heater
- Power Unit Weather Shield or Cover
- Container Guides
- Through Wall Ratchet Kit

Ask Your Local Dealer For Additional Options

!CAUTION! This Equipment Should Be Operated By Properly Trained Personnel. Improper Use, Misuse or Lack of Maintenance could cause injury to people and/or property. Photos used in this brochure are illustrative only. Due to its commitment to quality, SP Industries' specifications are subject to change without notice to accommodate improvements to its equipment. Information contained within this literature is intended to be the most accurate available at the time of printing.

Distributed By:



SP INDUSTRIES, INC.
2982 Jefferson Rd.
Hopkins, MI 49328
www.sp-industries.com

Phone: 616-793-3232
Toll Free: 800-592-5959
Fax: 616-793-7451
E-mail: info@sp-industries.com