

Front & Rear Load Compaction Containers

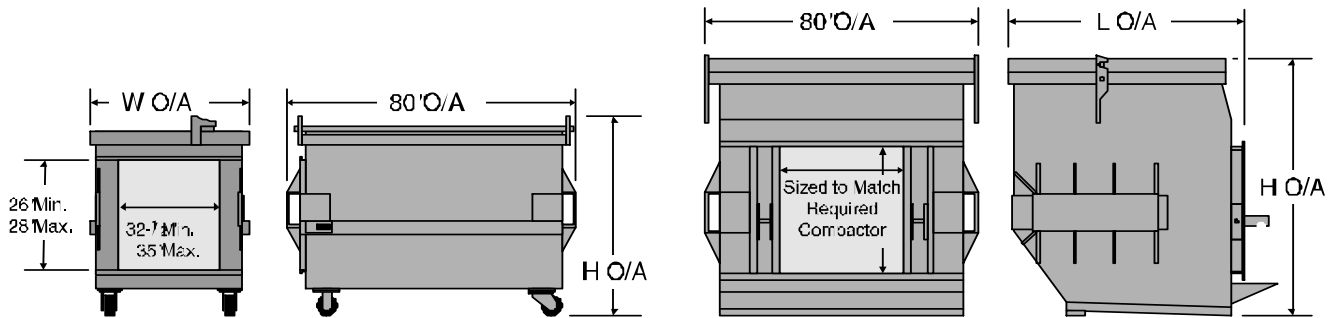

Model#	Capacity Cu. Yds.	O/A Length	O/A Width W	O/A Height H	Weight (Lbs.)
FC-200	2	80"	46"	51"	1,000
FC-300	3	80"	46"	65"	1,100

Model#	Capacity Cu. Yds.	O/A Length L	O/A Width W	O/A Height H	Weight (Lbs.)
FC-400	4	54"	81"	60"	1,570
FC-600	6	62"	81"	68"	1,750
FC-800	8	74"	81"	78"	2,050

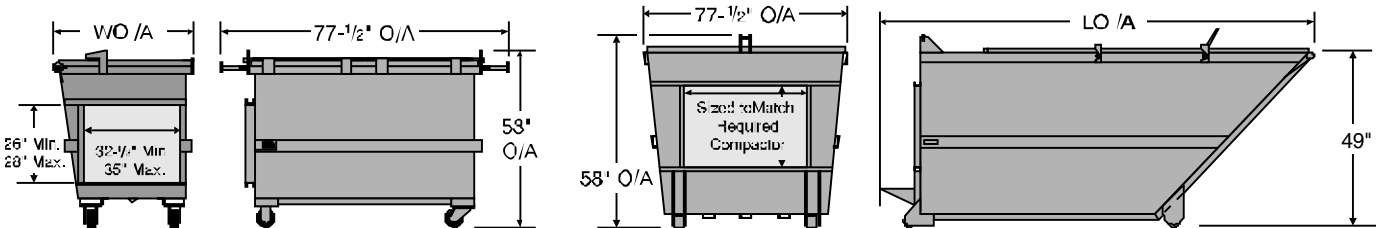

Model#	Capacity Cu. Yds.	O/A Length	O/A Width W	O/A Height H	Weight (Lbs.)
RC-200	2	77.5"	45"	57"	1,000
RC-300	3	77.5"	57"	57"	1,155

Model#	Capacity Cu. Yds.	O/A Length L	O/A Width W	O/A Height H	Weight (Lbs.)
RC-400	4	102"	77.5"	55"	1,485
RC-600	6	129"	77.5"	55"	1,900
RC-800	8	164"	77.5"	55"	2,400

Specifications

Sides, Floor & Lid: 10 GA Steel Plate

Sleeves: FL Machines only: 1/4" Bumper Plate, 1/4" formed plate 9-1/2" tall x 4-1/2" deep x 34" long, guss-
setted.

Cable Hookup: RL Machines only: (200 & 300 series) 1/2" plate, (400, 600 & 800 series) Two (2) 3/8" plate with 1" pins.

Machine Mating Surface: (200 & 300 series) 3" structural channel (400, 600 & 800) 3" channel or 3" tube steel.

Cover Hold Downs: RC-200 & 300 cinch tube, hand screw; RC-400, 600 & 800 six (6) locking pts.; FC-200 & 300 manual latch bar; FC-400, 600 & 800 Self-lock system.

Casters: FC-200 & 300 and RC-200 & 300 standard 2" x 6" 1,200# rated casters; RC-400, 600 & 800 front & rear rollers 4" OD x 1" wall tube with 1-7/8" pin and grease fittings.

Finish: Zinc chromate primer with enamel finish in choice of SP standard colors.



SP Industries, Inc. • 2982 Jefferson Rd. • Hopkins, Michigan 49328
Phone: 800-592-5959 • In Mich.: 269-793-3232 • Fax: 269-793-7451