



Industries Inc.



SCS-2031-OC-LP
Shown with an Optional
Side/Ground Load Hopper

SCS-LP Low Profile Self-contained

- **2 Cu. Yd. Capacity, Commercial, Low Profile, Compactor**
- **Available in Capacities from 23 to 39 Cubic Yards**
- **Equipped with SP Industries' Unique Standard Container Door Seal and Adjustable Door Hinge that Work Together to Reduce Leaks**
- **Nonproprietary Components for Ease of Maintenance & Service**
- **Industry Leading Warranty - 3 Years Ram and Frame Weldment, 1 Year Electrical and Hydraulic Components, Parts and Labor**
- **Meets or Exceeds Current ANSI Z245.2 Safety Standards**

CAUTION! This Equipment Should Be Operated By Properly Trained Personnel. Improper Use, Misuse or Lack of Maintenance could cause injury to people and/or property. Photos used in this brochure are illustrative only. Due to its commitment to quality, SP Industries' specifications are subject to change without notice to accommodate improvements to its equipment. Information contained within this literature is intended to be the most accurate available at the time of printing.



ENVIRONMENTAL INDUSTRY
ASSOCIATION



WASTE EQUIPMENT
TECHNOLOGY ASSOCIATION

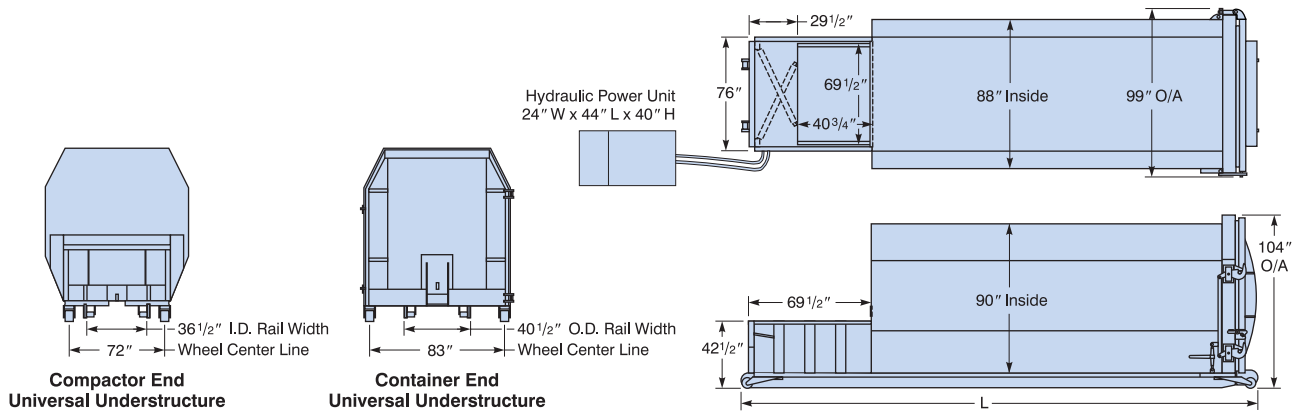

Capacity & Overall Length

Model Number	Overall Length (L)*	Capacity Cu. Yds.	Weight Lbs.
SCS-1623-LP	18' 4-1/2"	23	9,730
SCS-1827-LP	20' 4-1/2"	27	10,400
SCS-2031-LP	22' 4-1/2"	31	11,070
SCS-2235-LP	24' 4-1/2"	35	11,740
SCS-2439-LP	26' 4-1/2"	39	12,410

* The Overall Length shown is for a standard Universal Understructure.

Check that the Overall Length of the unit does not exceed the maximum length that the hoist can haul.

The following understructures will add to the overall length:

- Deadlift Understructure 2-1/2"
- Hooklift Understructure 11-1/2"
- Hooklift Understructure w/Fold-down,
Compactor End Hook 13-1/2"

Special Understructures may change the overall length of the machine.

Frame-pull Understructures are available and will shorten the length by 10" and reduce capacity by 1.3 cubic yards.

Specifications

- Compactor Capacity Mfg. Rating (Cu. Yds.) 2
- Compactor Capacity Wastec Type Rating (Cu. Yds.) 1.5
- Cycle Time (Seconds) 36
- Capacity Per Hour (Cu. Yds.) 148
- Clear Top Opening L x W (Inches) 40 x 68.5
- Ram Penetration (Inches) 5.5
- Ram Face Dimensions (Inches) 71-3/8 x 24
- Packing Force (Lbs.) 49,200
- Operating Pressure (PSI) 2,250

Standard Features

- Frame: Floor 3/8"
- Floor Supports TS 2" x 2" x 3/16"
- Side Plates 1/4"
- Side Supports TS 4" x 2" x 3/16"
- Breaker Bar L 6" x 6" x 3/4" & TS 2" x 6" x 3/16" w/Hinged Breaker Bar Teeth
- Ram Hold Down Bars 1" x 1-1/2" Bar
- Ram: Face Plate 1/2"
- Floor Plate 1/2"
- Side Plates 1/4"
- Top Plate 1/4"
- Top Supports C4" x 5.4#
- Guides Adjustable Nylatron Blocks
- Removable Access Panels
- Remote Power Unit
- Reservoir: 25 Gallon Capacity
- Oil - Suitable for Wide Temperature Range
- Oil Sight Gauge w/Thermometer
- Pump: 10 GPM,
Constant Displacement Vane Type
- Pressure Switching Soft-shift System
- Monitor Gauge (Advance/Full Load Indicator)
- Provisions for Disconnect on Left and Right
- Oil Spill Pan Under Both Disconnects
- UL Listed Electrical Components
- Motor: 10 HP 208/230/460 Tri-volt 3 Phase
- Controls In Main Panel:
 - Automatic Multicycle
 - Key Lock Start Button
 - Emergency Stop Button
 - Reverse Button
- Octagon Container
- Rear Container Door:
 - Full Seal w/Adjustable Hinges
 - Ratchet Locking System
- 4 Wheels w/Grease Fittings
- Double End Pick-up
- Inspection Port
- Standard Universal or Deadlift Understructure

SP Industries, Inc.
2982 Jefferson Rd. • Hopkins, MI 49328



Toll Free: 800-592-5959
E-mail: Info@sp-industries.com