



Stationary Compactor Standard & Optional Features

SP Industries, Inc. • 2982 Jefferson Rd. • Hopkins, MI 49328
Phone: 800-592-5959 • In Mich.: 269-793-3232 • Fax: 269-793-7451

INDEX

| | | | |
|---|------------|--|--------------|
| Index | 1 | Optional Features | 7-14 |
| Standard Features | 2-6 | Compactor Components | 7-12 |
| Compactor Components | 2-4 | 10,000# Drive On Deck | 7 |
| Breaker Bar | 2 | 5,000# Deck | 7 |
| Removable Access Panel | 2 | 750# Walk On Deck | 7 |
| Weather Hood | 2 | Deck Extensions | 7 |
| Ratchet Load Binders | 2 | Hand Rails | 7 |
| Ram Guides | 3 | Safety Gates | 7 |
| Rear Cross Member | 3 | Hoppers, Side or Rear Load | 8 |
| Hydraulic Cylinder Support | 3 | Dog House Type Hoppers | 8 |
| Frame Floor | 3 | Full Enclosures | 9 |
| Floor, Side & Top Supports | 3 | Bridge Chutes | 9 |
| Ram Hold Down Bars | 3 | Telescopic Chute | 9 |
| Ram Wiper | 3 | Security Chutes | 10 |
| Precrusher Gate | 4 | Access Doors | 10 |
| Control Features | 4-5 | Security Door and Thimble | 10 |
| Voltage Selection | 4 | Safety Interlock | 10 |
| Automatic Shut-Off | 4 | Through Wall Ratchet Kit | 10 |
| Automatic Multicycle Operation | 4 | Container Centering Guide Island | 11 |
| Key Lock Start | 4 | Container Centering Guide Rails | 11 |
| Pull-To-Start/Push-To-Stop Button | 4 | Container Centering Guide Rails with Stops | 11 |
| Full Load Indicator | 4 | Compactor Stands | 11 |
| Key Operated Jog Controls | 4 | Pinning Tunnel | 12 |
| Pinning Boost/Override System | 4 | Disinfectant Spray System | 12 |
| Remote Control Head | 5 | Control Features | 12-13 |
| Gate Up/Down Controls | 5 | U.L. Certified Panel | 12 |
| Automatic Safety Retract Start | 5 | Photo Electric Start System | 12 |
| Automatic/SMPC (Sustained Manual Pressure | | Infrared Start System | 12 |
| Control) Selector Switch | 5 | Advance Full Load Indicator | 12 |
| Ram Position Switch | 5 | Key Operated Jog Controls | 12 |
| Power Unit & Components | 5-6 | Pinning Boost/Override System | 13 |
| Remote Power Unit with Power Cable | 5 | Remote Control Head | 13 |
| Motors | 6 | Code Start System | 13 |
| Oil Reservoir | 6 | Security Latch | 13 |
| Hydraulic Hose | 6 | Low Oil/High Temperature Indicator Light | 13 |
| Hydraulic Oil | 6 | Thermo Oil Heater | 13 |
| Wet Armature Solenoid Directional Control | | Power Unit & Components | 14 |
| Valve | 6 | Oil Pressure Gauge | 14 |
| Constant Displacement Vane Pump | 6 | Monitor Gauge | 14 |
| Hi/Lo Pump | 6 | TEFC Motor | 14 |
| Cylinder(s) | 6 | Power Unit Cover | 14 |
| Limit Switch | 6 | Weather Shield | 14 |
| Pressure Switch | 6 | | |
| Soft Shift Hydraulic Valves | 6 | | |

STANDARD FEATURES

Compactor Components

A steel cross member at the top front of the compaction opening which breaks oversized material down in size so it will fit into the compaction container opening. Our breaker bars have been designed to withstand a minimum of three times the maximum compactor force rating per the ANSI Z245.2 safety standards. Material wedged between the ram and breaker bar will create forces much greater than the compaction force. For instance, the breaker bar on a machine with a compaction force of 102,000 lbs. is engineered to withstand forces greater than 306,000 lbs. At those forces ram movement will stop or the material will give before the breaker bar will be permanently deformed.

Bolted on top and/or rear of the compactor for access to internal compactor components such as the cylinder(s), limit switch, guide shoes and hydraulic piping. **Lockout/tag out procedure must be followed before removing access panels per OSHA guidelines.**

Standard on the CP-4001, CP-4002 and CP-6002. The weather hood keeps the weather out and allows easy access to internal components of the compactor. **Lockout/tag out procedure must be followed before removing access panels per OSHA guidelines.**

To secure a compaction container or trailer to the compactor. Heavy duty swivel hooks for a positive machine-to-container hook up. The ratchet load binders are designed to withstand more than the force generated by the hydraulic system. Containers attached to this system must also be designed to withstand the same or greater forces.

Breaker Bar

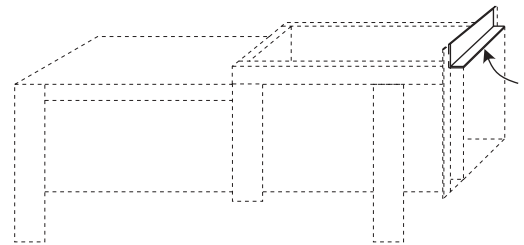

Removable Access Panel

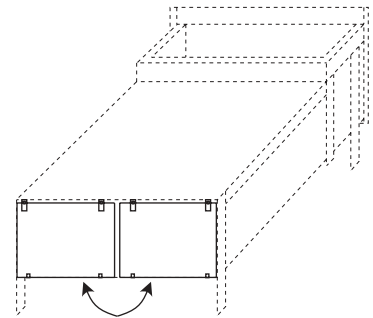

Weather Hood/Access Panel

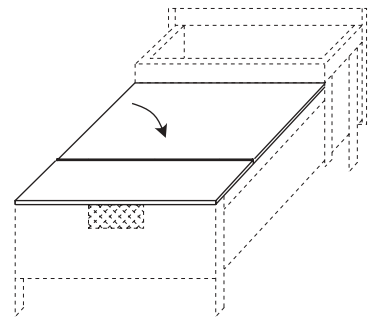

Ratchet Load Binders

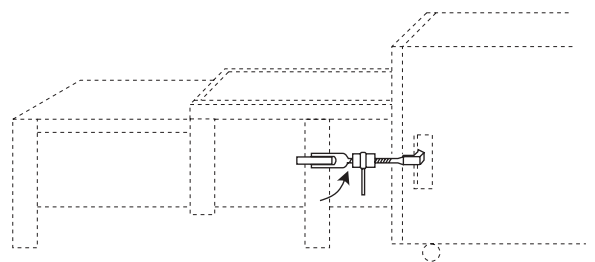

Ram Guides

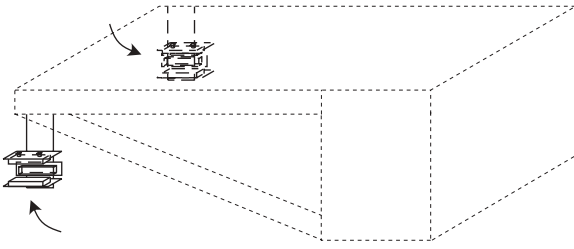

Nylatron pads on each side of the ram guide the ram inside the frame and maintain the ram against bucking and fishtailing. The wear guides are adjustable and if needed replaceable. These wear pads are like brake shoes and require adjustment or replacement based upon the usage of the machine.

Rear Cross Member (Thrust Beam)

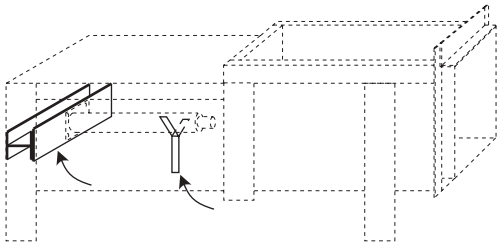

A combination beam and plate weldment to which the cylinder(s) is/are bolted (foot mounted). This member is designed to withstand more than the forces capable of being generated by the hydraulic power source per the ANSI Z245 series safety standards.

Hydraulic Cylinder Support

Used on the CP-4001, CP-4002, CP-6002, CP-8002, CP-13001 and all PC models to support the cylinder(s). They support the longer cylinders keeping the cylinder and rod in line when the cylinder rod is extended, this prolongs the life of the seals and piston rings.

Frame Floor

AR 235 Abrasion resistant work hardening plate is standard on all compactors and precrushers. The AISI grade steel increases in hardness with use. Special Hardox AR floors are available upon request.

Floor, Side & Top Supports

Structural steel channels, beams, angles, and tubes are used to provide the most reliable and strongest support.

Ram Hold Down Bars

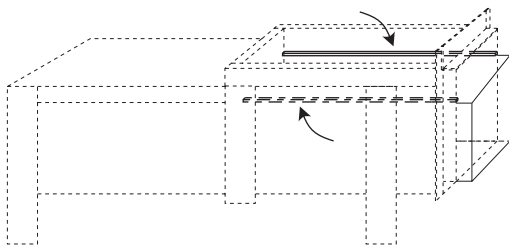

Steel bars running along the top of each side of the compaction chamber which hold the ram down during the compaction cycle.

Ram Wiper

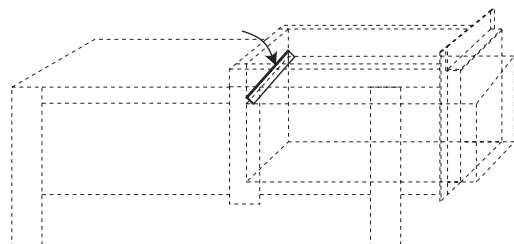

A hinged wear bar at the back of the compaction chamber which wipes debris off the ram top when it retracts into the compactor.

A standard feature on all precrusher/compactor units. It is a vertical gate at the front of the compaction chamber which, when closed, provides a steel wall for the material in the chamber to be crushed against by the ram. It is used for bulky material such as crates, barrels, white goods and pallets to reduce the volume of the material before compacting it into the container.

Precrusher Gate

Control Features

All motors up to 10 HP may be wired to connect to a 208, 230 or 460 volt, 3 phase, power supply source. Motors which are 15 HP or larger are manufactured to be wired for 230 or 460 only; however, 208 voltage motors are available up to 30 HP and must be specified on the order.

Voltage Selection

Caution: To change from one voltage to another, the motor and transformer must be rewired, primary fuses changed, motor starter changed, and the corresponding thermo overload protection (heater) must be changed. Larger wiring may be required if changing from higher to lower voltage.

When the container is full or the compactor is jammed during the forward stroke, the machine will automatically shut off within 60 seconds or less and a red indicator light will illuminate at the control station.

Automatic Shut-Off

The compactor can be set to run one or multiple cycles automatically when started. The number of cycles is determined by the setting on the cycle timer (1TR) located in the main control panel.

Automatic Multicycle Operation

The keyed switch is the Off/On power switch for compactor operation. When the switch is in the "Off" position, the system is off except for oil heaters. When the switch is in the "On" position the system is live and the machine can be started. To disable the complete system the main disconnect must be locked out and tagged per OSHA standards.

Key Lock Start

The mushroom push/pull type button is used to begin the cycling operation. When the Key Lock Start Switch is in the "On" position and the Pull-To-Start/Push-To-Stop Button is pulled, the cycle starts. When the button is pushed, compactor operation instantly stops. The button must be pulled to the neutral center position then pulled to resume operation.

Pull-To-Start/Push-To-Stop Button

A light located inside the mushroom start/stop button illuminates when the container is full or the compactor is jammed in the forward position. The indicator is a separate light on precrusher/compactors and is not available on self-contained compactor/container, pressure switching systems.

Full Load Indicator

These controls allow manual forward and backward operation of the ram. The controls are normally mounted on two, three, and four yard industrial stationary compactor models. As an option, controls can be mounted on the machine at the left or right front of the charge opening. Note: These controls will not override the shut-off pressure. A Pinning Boost/Override control must be used to override shut-off pressure.

Key Operated Jog Controls

Pinning Boost/Override System

This key operated control allows manual operation of the ram. The Pinning Boost Override system gives the system added operating pressure to clear the compaction chamber when the container system is full and allows the operator to pin off a container when optional pinning tunnels are provided. These controls are standard for 6,7,8, and 13 cu. yd. compactors and all precrusher/compactors and are normally mounted on the machine near the front left of the charge chamber.

Remote Control Head

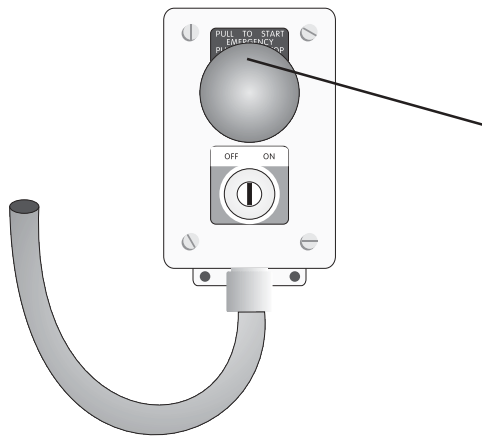

The remote control head is standard on all industrial compactors and is optional on commercial compactors. Remote controls are supplied with ten feet of electrical flexible conduit, longer lengths are available. The NEMA 12 control box includes the Key Lock Off/On Switch and Pull-To-Start/Push-To-Stop Button with Full Load Indicator.

The Full/Jam Indicator Light is located in the center of the Pull-To-Start/ Push-To-Stop Button.

Precrusher Gate Up/Down Controls

These controls are located with the pinning boost/override controls and allow manual up and down movement of the precrusher gate.

Automatic Safety Retract Start

This built in safety feature causes the ram to retract when the machine is started unless the ram is already in the retracted position, then the ram will move forward when the machine is started. Note: This feature is not available on self-contained compactor/container models which utilize a manual reverse button.

Automatic/SMPC (Sustained Manual Pressure Control) Selector Switch

This toggle switch, located inside the main control panel, allows the compactor to be operated in either the automatic or SMPC mode. A compactor must have an ANSI/OSHA approved hopper or guard system installed to be shipped in the automatic position. This item is standard on most machines and optional on units such as the self-contained compactors/containers, precrusher compactor models, CP-711 and the APT-331.

Ram Position Switch

This toggle switch, located inside the main control panel, stops the ram in the desired position, front or rear of the compaction chamber, at the end of the cycle. Note: This feature is not available on self-contained compactors/containers, precrusher/compactor models, CP-711 and APT-331 models.

Power Unit & Components

Remote Power Unit with Power Cable

Completely independent power unit with easily accessible components. Note: Proprietary components available only from SP Industries, Inc.

1725 RPM, T-Frame, O.D.P. (Open Drip Proof), 3 phase, 60 hertz, C-Face.

The oil capacity, being approximately 2-1/2 times larger than the rated pump output, allows for proper oil cooling and ample time to shut down the system if a hydraulic line should burst to prevent dry running of the pump. The reservoir includes an oil level gauge, thermometer, breather, and clean-out port.

All hydraulic hoses are SAE rated for 2000 PSI minimum working pressure and 8000 PSI minimum burst pressure.

The hydraulic oil is a premium grade oil with a viscosity index of 100 or higher and a viscosity of 120 to 150 SUS at 100° F. This fluid has anti-foam, anti-wear, water separating additives, and a pour point of - 30° F.

A wet armature solenoid directional control valve has self lubricating, movable solenoid parts which provide longer solenoid life.

The low noise vane type pump keeps the normal noise level below 85 db's and maintains consistent system pressure and cycling.

This type of pump is used on our precrusher/compactor. It produces high volume at low PSI, at 1,400 PSI it diverts the high flow pump oil to the tank and continues with the low oil flow only.

All cylinders up to 7" utilize a two piece polyester elastomer seal system that is most tolerant to dirt and contamination with excellent wearing resistance. The 10" cylinders utilize a four piece TPE seal system with thermo plastic anti-extrusion rings.

The stroke of the cylinder(s) is controlled by one, double acting limit switch. The switch is set to reverse the cylinder stroke before the rod bottoms out which prevents hydraulic hammering and prolongs the life of the hydraulic system.

In order to eliminate the electrical disconnect on self-contained compactor/containers, the cylinder(s) is(are) controlled by pressure switches which reverse the rod movement when maximum system pressure is reached.

Self-contained compactor/containers are equipped with pressure switches; therefore, a soft shift valve is used to relieve the hydraulic shock when reversing the cylinder rod.

Motors

Oil Reservoir

Hydraulic Hose

Hydraulic Oil

Wet Armature Solenoid Directional Control Valve

Constant Displacement Vane Pump

Hi/Lo Pump

Cylinder(s)

Limit Switch

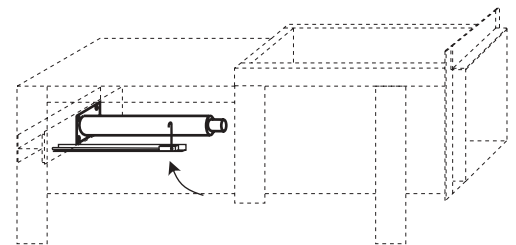

Pressure Switch

Soft Shift Hydraulic Valves

OPTIONAL FEATURES

Compactor Components

10,000# Drive On Deck

Available on models of stationary compactors CP-2101 and larger for rear loading with a forklift or cart dumper system.

5,000# Deck

Available on SC and SCS models of self-contained compactor/containers.

750# Walk On Deck

Available on all models for rear hopper loading systems. Cannot support the weight of a forklift or cart dumper.

Deck Extensions

For joining machine deck with building dock and providing necessary clearance for access to the rear of the machine.

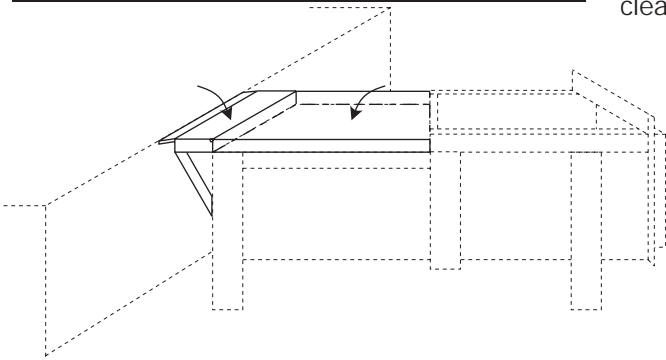

Hand Rails/Toe Rails

Safety approved 42" height per OSHA and ANSI recommended safety standards.

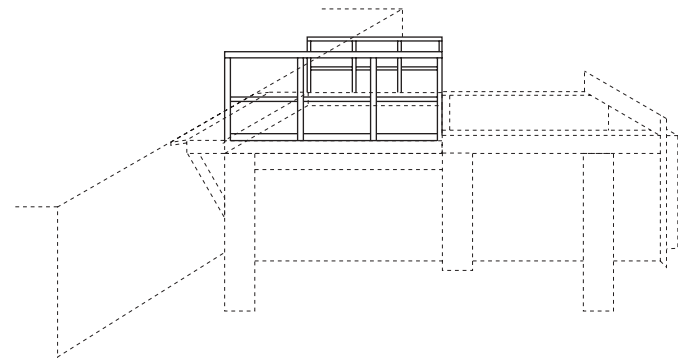

Safety Gates

Used to close off loading areas and equipped with a safety interlock switch to ensure that the operator is at a safe distance before the compactor is started per ANSI Z245.2 series specifications.

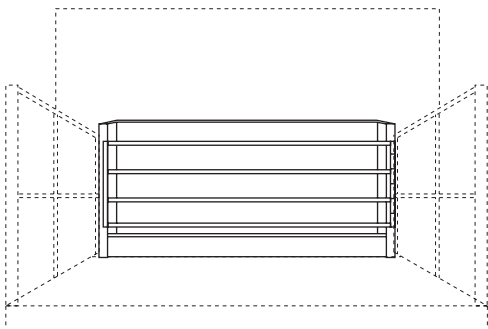

Gate attached to a rear load hopper.

Standard size hoppers are available for all stationary compactors, precrusher/compactors and self-contained compactor/containers. See the standard hopper charts for sizes. Special hoppers are available on request. All meet ANSI Z245.2 series specifications.

Hoppers, Side or Rear

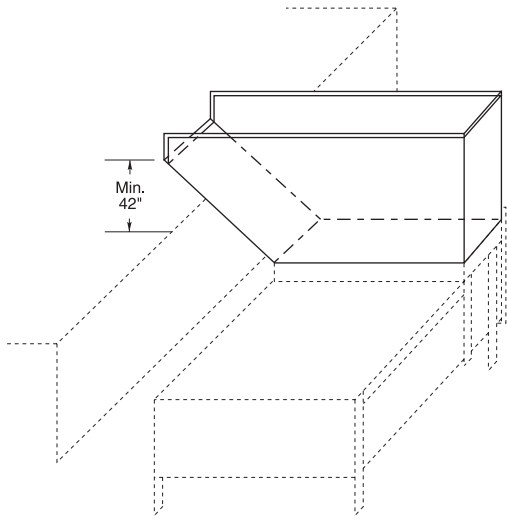

Side load hopper with a 42" load lip from a dock.

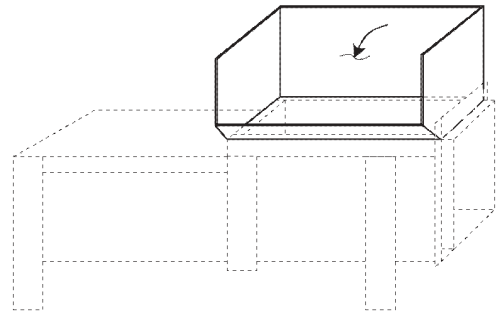

Side load hopper from the ground.

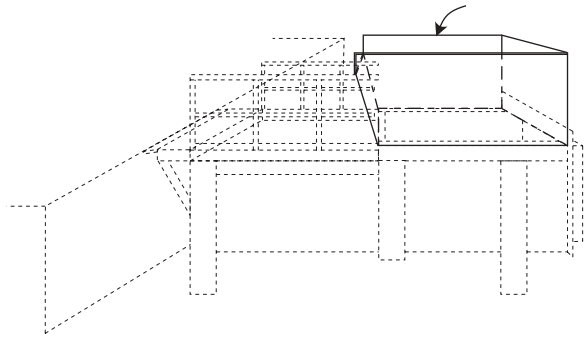

Rear load hopper with a 42" load lip from a deck.

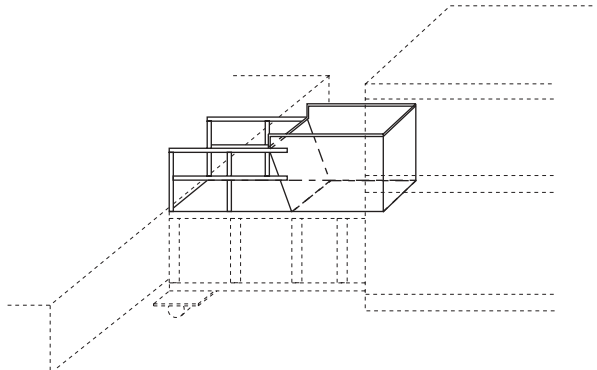

Rear load hopper with a 42" load lip from a deck on an SC model self-contained compactor container.

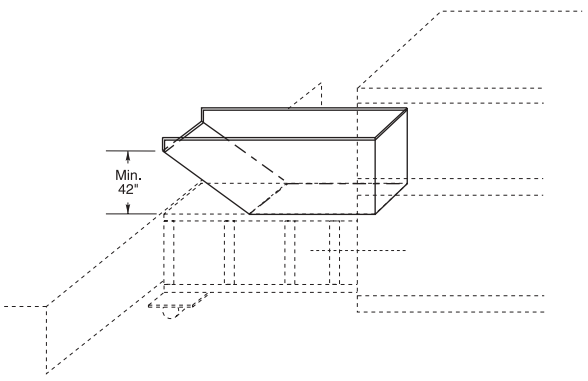

Rear load hopper with a 42" load lip from a dock on an SCS model self-contained compactor container.

Enclosed hoppers are available for loading from rear and from either or both sides of the compactor. The doors must be equipped with safety interlocks to stop the machine when the door is opened if the loading height is below 42" or a pinch point or material can be reached.

Dog House Type Hoppers

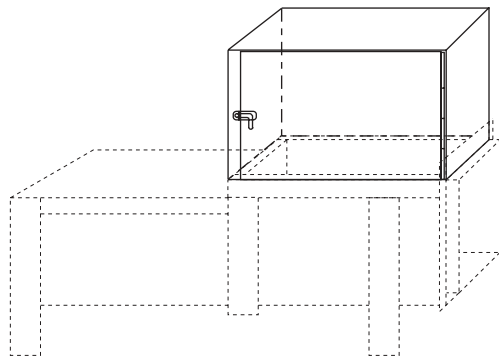

Full Enclosures

These enclosures are designed to completely cover the compactor deck and chamber opening to close off the area and reduce heat or air-conditioning loss from the building and protect the operator from the weather.

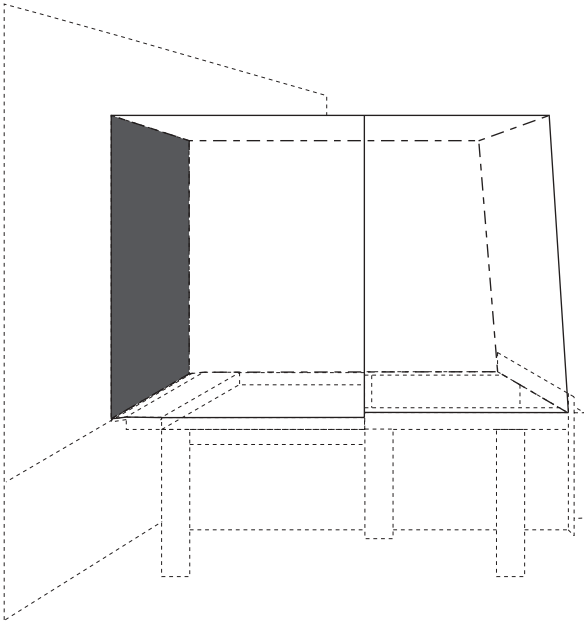

Bridge Chutes

Bridge chutes are available for side or rear loading of self-contained compactor/containers. These chutes allow the SC unit to be removed from under the chute for hauling. Loading doors of chutes must be interlocked per ANSI/OSHA guidelines.

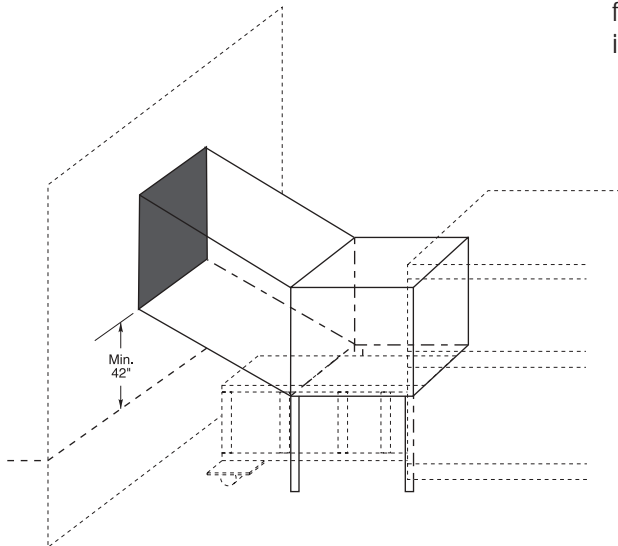

Telescopic Chute

Telescopic chutes are available for side loading of self-contained compactor/containers. These chutes are attached to the compactor and slide away from the wall opening to allow the SC unit to be removed for hauling. Loading doors of chutes must be interlocked per ANSI/OSHA guidelines.

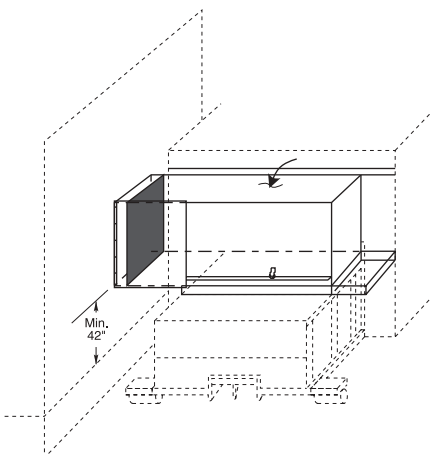

Fully enclosed chutes are available for side or rear loading of a stationary compactor from the inside of a building. Loading doors of chutes must be interlocked per ANSI/OSHA guidelines.

An interlocked access door is available on a chute to allow access for cleaning the chute or clearing a jam. When the door is opened, the compactor will shut off.

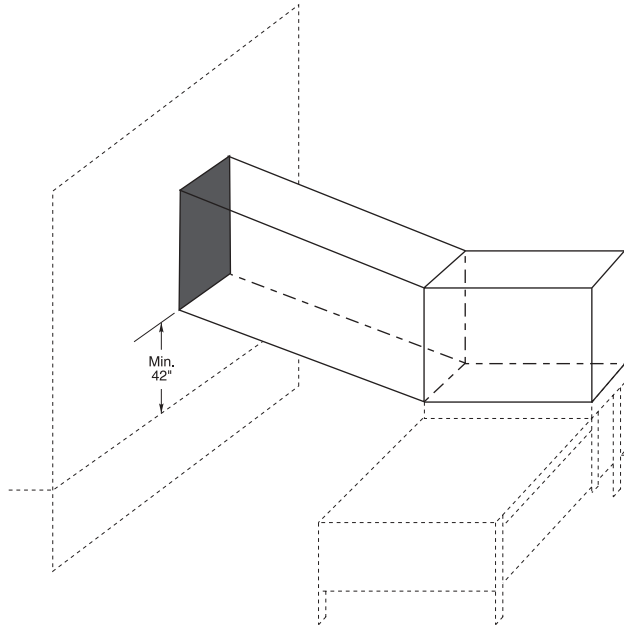

Side load security chute.

Used as a through the wall access to a security chute. The door can be locked for security. A loading height of at least 42" is required for walking/working surface safety standards and must be supplied with a safety interlock per ANSI Z245 series standards.

A safety switch is mounted on a chute or hopper door, or hopper gate when guarding or loading height is below 84" or pinch points can be reached. The interlock switch will only allow the machine to run when the door or gate is closed. Machine operation will stop when the door or gate is opened.

The kits have special load binders that allow the hauler to unhook and re-hook the container, on the outside of the building, from the compactor, on the inside of the building. This eliminates the need for the hauler to have access to the interior of the building. Shut off controls should be located outside at the hookup area per ANSI Z245 series standards.

Security Chutes

Access Doors

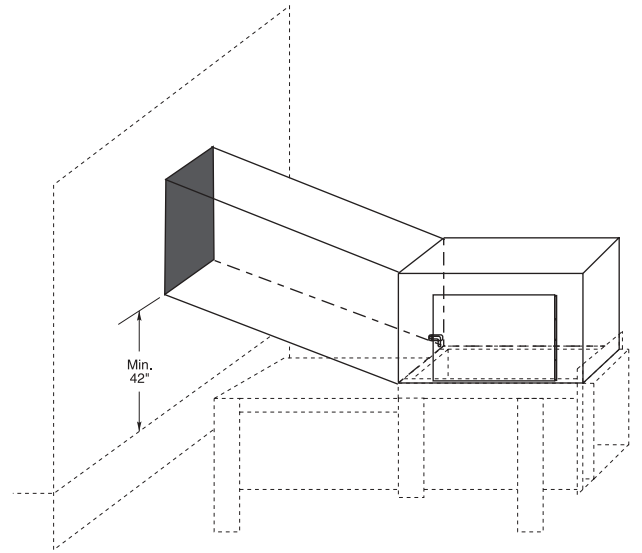

Rear load security chute with an access door.

Security Door and Thimble

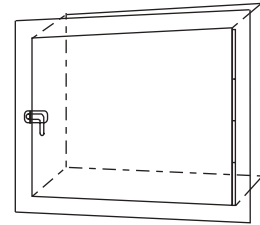

Safety Interlock

Through Wall Ratchet Kit

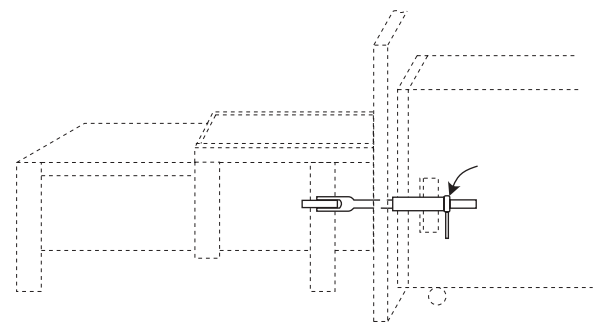

Container Centering Guide Island

A covered island which aligns the container with the compactor when the container is rolled back into position for attachment to the compactor.

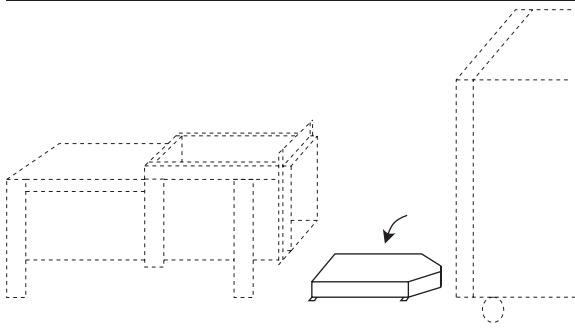

Container Centering Guide Rails

Various lengths are available to align the container with the compactor when it is rolled back into position for attachment to the compactor.

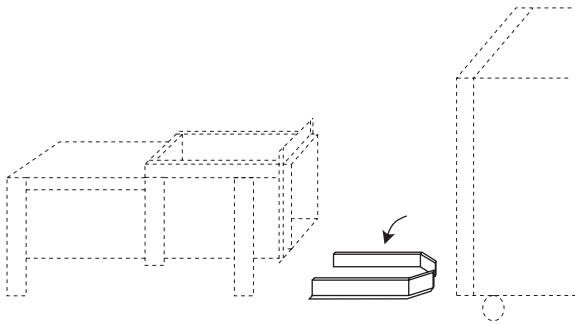

Container Centering Guide Rails w/Stops

Guide rails with stops are available to align self-contained compactor/containers with their loading systems. Systems available include angle or channel type guides.

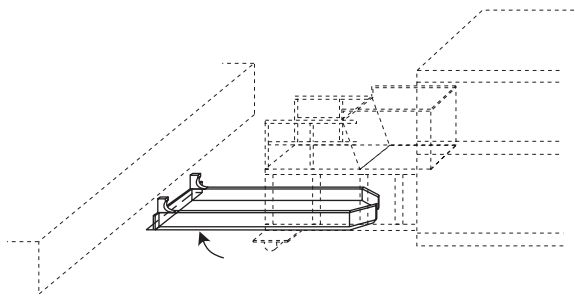

Compactor Stands

These stands are used to raise the compactor to the loading height of a transfer trailer or for special applications to pack into the top of a compaction containers.

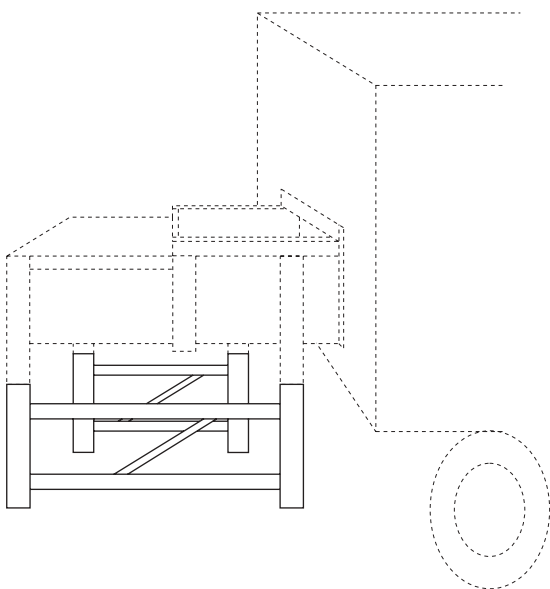

A hinged tunnel mounted on the face of the ram which aligns with holes in the door of the attached container. This allows a chain, cable or pinning sword to be inserted through the holes in the container door and between the ram face and the refuse to retain the refuse from spilling out of the container when the container is pulled away from the compactor.

Pinning Tunnel

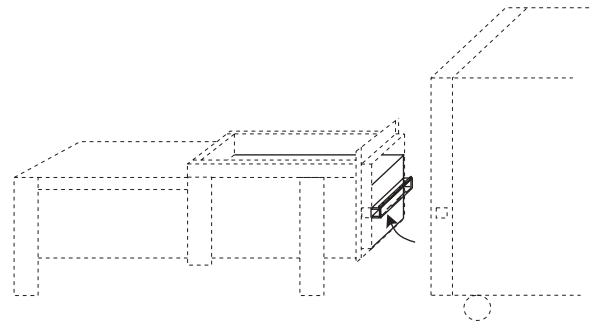

A pre-measured intermittent spray helps to eliminate offensive odors and/or vermin. One aerosol can is included with our standard canister system.

Disinfectant Spray System

Control Features

The main electrical controls and panel are inspected and certified by a U.L. representative as conforming to U.L. #508 Standard for Safety for Industrial Control Equipment.

U.L. Certified Panel

A system which starts a compaction cycle when the light beam across the chamber opening is interrupted. The system is supplied with a safety delay warning feature (per current ANSI Z245.2 specifications) which includes a 5 second, audible warning buzzer which sounds and a 15 second flashing strobe light that operates before the machine begins cycling.

Photo Electric Start System

A system which uses an infrared emitter and receiver to begin the compaction cycle. When the signal is broken the cycle begins. The system is supplied with a safety delay warning feature (per current ANSI Z245.2 specifications) which includes a 5 second, audible warning buzzer, and a 15 second, flashing strobe light that operates before the machine begins cycling.

Infrared Start System

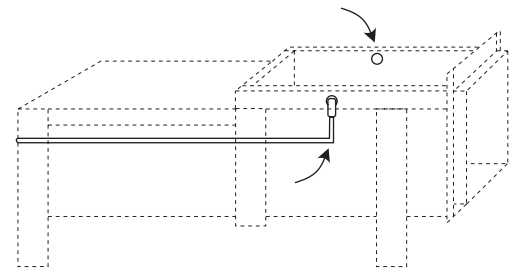

An adjustable pressure actuated switch turns on an amber light in the control head or panel when the container is approximately 95%, 85%, or 75% full, a relay keeps the light on until the circuit is broken. This allows time for the hauler to be contacted before the container is completely full.

Advance Full Load Indicator

These controls allow manual forward and backward operation of the ram. Note: These controls will not override the shut-off pressure. A Pinning Boost/Override Control must be used for this operation.

Key Operated Jog Controls

Pinning Boost/Override System

These key operated controls allow manual operation of the ram. The Pinning Boost Override system gives the system added operating pressure to clear the compaction chamber when the container or trailer is full and allows the operator to pin off a container when optional pinning tunnels are provided. The controls are mounted on the machine near the front left of the charge opening for all compactors and precrusher/compactor models.

Remote Control Head

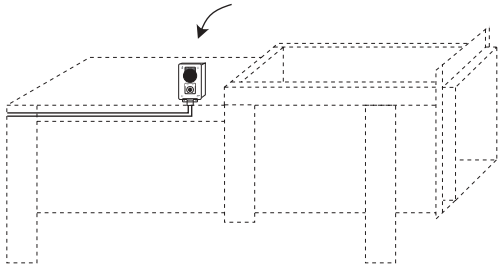

A remote control head can be supplied as a second control for an industrial compactor in order to operate the machine from more than one location, or it can be supplied as the main control head for a system with standard panel mounted controls. Controls must be mounted in accordance to ANSI Z245.2 safety standards.

Code Start System

A keyless/coded start system which only allows access to compactor operation after a four digit code has been entered.

Security Latch

An electronic locking system which prevents unauthorized access to a compactor's dog house hopper and unauthorized use of the compactor. It is often used in conjunction with a code start system or after market monitor systems.

Low Oil/High Temperature Indicator Light

If the hydraulic oil in the power unit becomes dangerously low, a red light in the main control panel will indicate the condition and the power unit will shut down. If the power unit system temperature becomes dangerously high, a red light in the main control panel will indicate the condition and the power unit will shut down. The system will not operate until the oil level is increased or the temperature has been reduced.

Thermo Oil Heater

The thermo oil heater is a thermostatically controlled hydraulic oil heater preset at a temperature of 65° F which facilitates operation in cold climates.

Power Unit & Components

An oil filled gauge capable of measuring pressures from 0 to 3,000 PSI.

Monitor Gauge - An oil pressure gauge with color coded indicators for 50%, 75% and 100% of the maximum system pressure. Two models are available; one with the 100% full at 1800 to 2100 PSI, the other with 100% full at 1500 to 1700 PSI.

Oil Pressure Gauge

Monitor Gauge

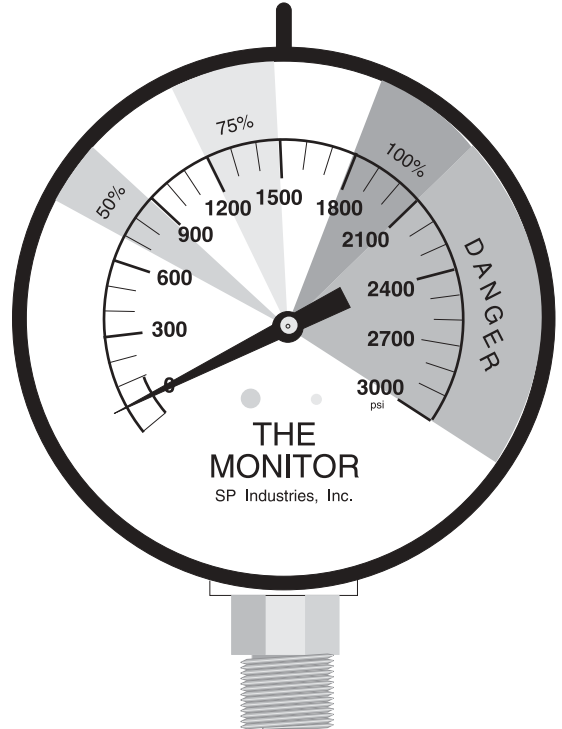

Totally Enclosed Fan Cooled motor.

A power unit cover shields and protects the power unit from inclement weather and discourages vandalism. A pad lock may be placed on the door for added security.

TEFC Motor

Power Unit Cover

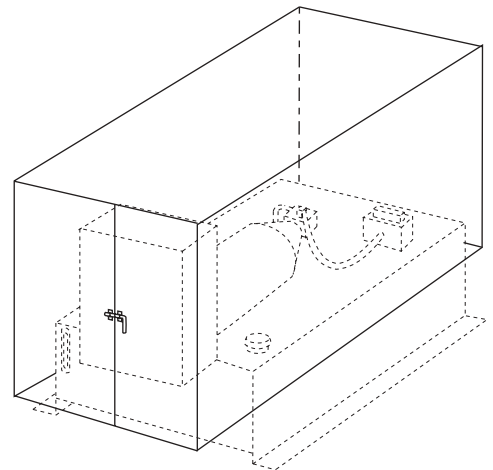

A power unit cover with open ends that protects the power unit from inclement weather.

Weather Shield

